



RE6503/RE7503/RE8603/RE9803

RS232 & LAN Protocol Installation Guide



Table of Contents

Introduction	2
Wire arrangement	3
RS232 pin assignment	3
Communication setting	4
Command message reference	4
Connections and communication settings	4
RS232 serial port connection	4
RS232 via LAN	5
RS232 via HDBaseT	5
Protocol Command Description	5
Set-function listing	6
Set-function description	6
Set-function format	6
Set-function table	8
Get-function listing	14
Get-function description	14
Get-function format	14
PC Get-function command to IFP	17

Introduction

This document describes the hardware interface spec and software protocols of RS232 interface communication between Commercial Display and PC or other control unit with RS232 protocol. This set protocol allow users to assign the ID in the command to control the specify ID monitor. The set protocol contains two sections command: Set-Function and Get-Function



In this document, "PC" represents all the control units that can send or receive the RS232 protocol command.

Wire arrangement

Wire Arrangement		
P1	Color	P2
1	Black	1
2	Brown	3
3	Red	2
4	Orange	4
5	Yellow	5
6	Green	6
7	Blue	7
8	Purple	8
9	Gray	9
Case	Drain wire	Case

RS232 pin assignment



Pin	Description	Pin	Description
1	NC	2	RXD
3	TXD	4	NC
5	GND	6	NC
7	RTS	8	CTS
9	NC		



Use of straight cable requires use with PC.

Communication setting

Baud rate select: 9600bps (fixed)/ Data bits: 8 bits (fixed)

Parity: None (fixed)/ Stop Bits: 1(fixed)

Command message reference

PC sends to Monitor command packet followed by "CR". Every time PC sends control command to the Monitor, the Monitor shall response as follows:

1. If the message is received correctly, it will send "+" (02Bh) followed by "CR" (00Dh).
2. If the message is received incorrectly, it will send "-" (02Dh) followed by "CR" (00Dh).

Connections and communication settings

Choose one of the connections and set up properly before RS232 control.

RS232 serial port connection

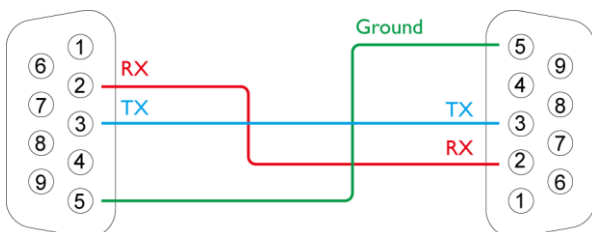
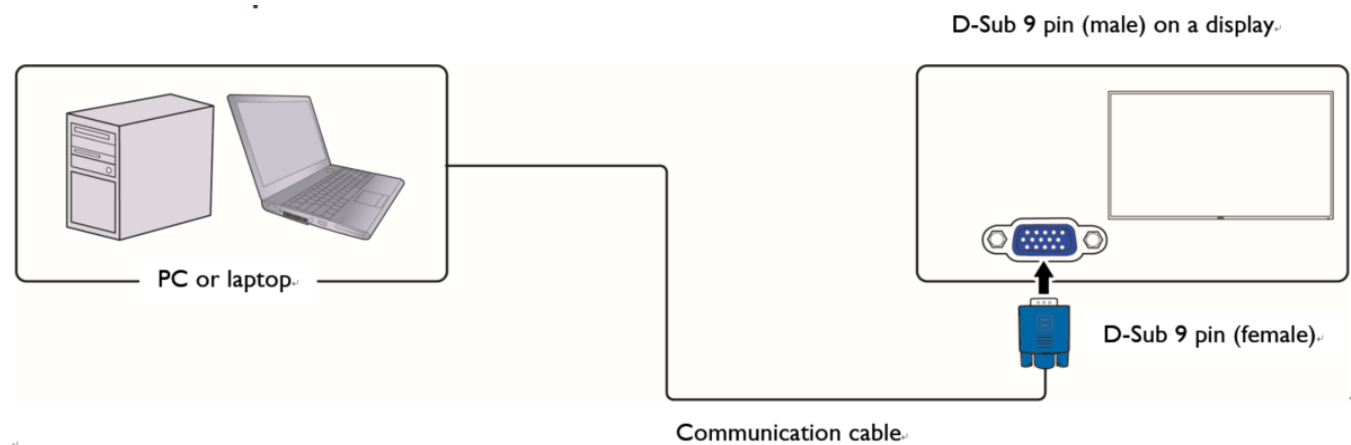

RS232 via LAN

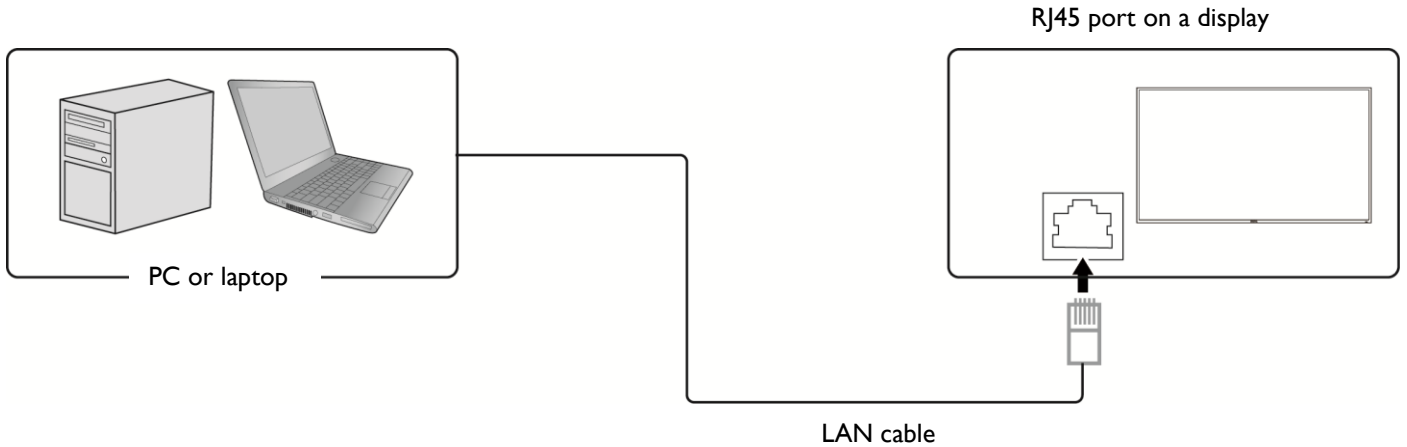

 Find the Wired LAN IP address of the connected display from the OSD menu and make sure the display and the computer are within the same network.

IP Protocol Port: 4660

RS232 via HDBaseT

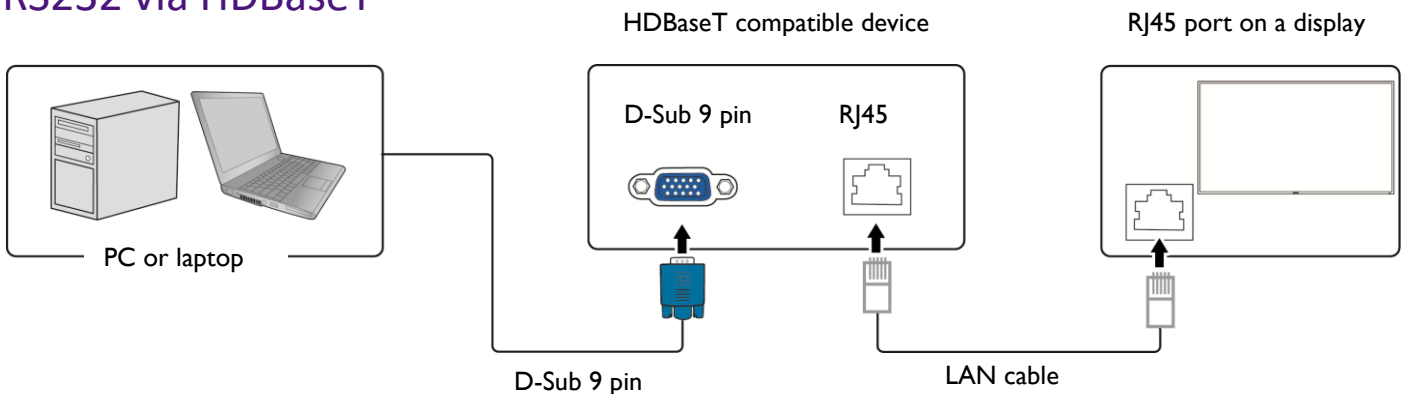

Protocol Command Description

Item	Description
Length	Total Bytes of Message excluding "CR"
TV ID	Identification for each of TV TV ID is "01" for LAN control & RS232 control
Command Type	Identify command type, "s" (0x73h): Set Command "g" (0x67h): Get Command "r" (0x72h): Reply Command "+" (0x2Bh): Valid command Reply "- " (0x2Dh): Invalid command Reply
Command	Function command code: One byte ASCII code

Value [1~3]	Three bytes ASCII that defines the value
CR	0x0D

Set-function listing

The PC can control the LCD Monitor for specific actions. The Set-Function command allows you to control the LCD monitor behavior in a remote sit through the RS232 port. The Set-Function packet format consists of 11 bytes.

Set-function description

Item	Description
Length	Total Bytes of Message excluding "CR"
TV ID	Identification for each of TV TV ID is "01" for LAN control & RS232 control
Command Type	Identify command type, "s" (0x73h): Set Command
Command	Function command code: One byte ASCII code
Value [1~3]	Three bytes ASCII that defines the value
CR	0x0D

Set-function format

Send: (Command Type="s")

Name	Length	ID	Command type	Command	Value1	Value2	Value3	CR
Byte count	1 Byte	2 Byte	1 Byte	1 Byte	1 Byte	1 Byte	1 Byte	1 Byte
Bytes order	1	2~3	4	5	6	7	8	9

Reply: (Command Type="+" or "-")

Name	Length	ID	Command type	CR
Byte count	1 Byte	2 Byte	1 Byte	1 Byte
Bytes order	1	2~3	4	5

Example 1: Set Brightness as 76 and this command is valid.

Send (Hex Format)

Name	Length	ID	Command type	Command	Value1	Value2	Value3	CR
Hex	0x38	0x30 0x31	0x73	0x24	0x30	0x37	0x36	0x0D

Reply (Hex Format)

Name	Length	ID	Command type	CR
Hex	0x34	0x30 0x31	0x2B	0x0D

Example 2: Set Brightness as 176 and this command is NOT valid.

Send (Hex Format)

Name	Length	ID	Command type	Command	Value1	Value2	Value3	CR
Hex	0x38	0x30 0x31	0x73	0x24	0x31	0x37	0x36	0x0D

Reply (Hex Format)

Name	Length	ID	Command type	CR
Hex	0x34	0x30 0x31	0x2D	0x0D

Example 3: Set Balance as 50 this command is valid.

Send (Hex Format)

Name	Length	ID	Command type	Command	Value1	Value2	Value3	CR
Hex	0x38	0x30 0x31	0x73	0x39	0x30	0x35	0x30	0x0D

Reply (Hex Format)

Name	Length	ID	Command type	CR
Hex	0x34	0x30 0x31	0x2D	0x0D

Example 4: Set Balance as 115 this command is Not valid.

Send (Hex Format)

Name	Length	ID	Command type	Command	Value1	Value2	Value3	CR
Hex	0x38	0x30 0x31	0x73	0x39	0x31	0x31	0x35	0x0D

Reply (Hex Format)

Name	Length	ID	Command type	CR
Hex	0x34	0x30 0x31	0x2D	0x0D

Set-function table

Set Function	Len	ID	Cmd Type	Cmd Code (Hex)	RS232 (ASCII Bytes)	LAN (ASCII Bytes)
Power	8		s	21		000 : Monitor Off
					001 : On	001 : Monitor On
					002 : Standby (or android off)	002 : Standby (android off)
					003 : Reboot	003 : Reboot
Video Source	8		s	22	000 : VGA	000 : VGA
					001 : HDMI1	001 : HDMI1
					002 : HDMI2	002 : HDMI2
					021 : HDMI3	021 : HDMI3
					051 : Type-C (RE03)	051 : Type-C (RE03)
					101 : Android	101 : Android
					103 : OPS	103 : OPS
					108 : Wi-Fi Source	108 : Wi-Fi Source
Contrast	8		s	23	000 ~ 100	000 ~ 100
Brightness	8		s	24	000 ~ 100	000 ~ 100
Picture reset	8		s	26	000 :	000 :
Aspect Ratio	8		s	31	000 : 16:9	000 : 16:9
					002 : PTP	002 : PTP
Language	8		s	32	000: English	000: English
					001: Français	001: Français
					002: Español	002: Español
					003: 繁中	003: 繁中
					004: 簡中	004: 簡中
					005: Português	005: Português
					006: German	006: German
					007: Dutch	007: Dutch
					008: Polish	008: Polish
					009: Russia	009: Russia
					010: Czech	010: Czech
					011: Danish	011: Danish
					012: Swedish	012: Swedish
					013: Italian	013: Italian
					014: Romanian	014: Romanian
					015: Norwegian	015: Norwegian
016: Finnish	016: Finnish					

					017:Greek	017:Greek
					018:Turkish	018:Turkish
					019:Arabic	019:Arabic
					020:Japanse	020:Japanse
					021: Thailand	021: Thailand
					022: Korean	022: Korean
					023 : Hungarian	023 : Hungarian
					024 : Persian	024 : Persian
					025 : Vietnamese	025 : Vietnamese
					026 : Indonesia	026 : Indonesia
					027 : Hebrew (希伯來語)	027 : Hebrew (希伯來語)
Sound Mode	8		s	33	000 : Movie	000 : Movie
					001 : Standard	001 : Standard
					002: Custom (User)	002: Custom (User)
					003 : Class	003 : Class
					004 : Meeting	004 : Meeting
Volume	8		s	35	000 ~ 100	000 ~ 100
Mute	8		s	36	000: Off	000: Off
					001: On	001: On
Treble	8		s	37	000~100	000~100
Bass	8		s	38	000~100	000~100
Balance	8		s	39	000~100	000~100
Sound reset	8		s	3B	000	000
Reomte control command	8		s	40	000 : Vol +	000 : Vol +
					001 : Vol -	001 : Vol -
					010 : Remote 上	010 : Remote 上
					011 : Remote 下	011 : Remote 下
					012 : Remote 左	012 : Remote 左
					013 : Remote 右	013 : Remote 右
					014 : Remote OK	014 : Remote OK
					020 : Remote Menu Key	020 : Remote Menu Key
					021 : Remote Input source	021 : Remote Input source
					022 : Remote Exit	022 : Remote Exit
					031 : Blank	031 : Blank
					032 : Freeze	032 : Freeze
					IR Control	8
001: Enable	001: Enable					
Button&IR Control	8		s	43	000: Disable	000: Disable
					001: Enable	001: Enable
Button Control	8		s	45	000: Disable	000: Disable

					001: Enable	001: Enable
All Reset	8		s	7E	000	000
Screen Reset	8		s	7F	000	000
Picture Mode	8		s	81	000: Standard	000: Standard
					001: Bright	001: Bright
					002 : Soft	002 : Soft
					003 : ECO	003 : ECO
					005 : Custom 1	005 : Custom 1
					006 : Custom 2	006 : Custom 2
					007 : Custom 3	007 : Custom 3
Backlight	8		s	84	000 ~ 100	000 ~ 100
DCR	8		s	85	000: Off	000: Off
					001: On	001: On
Color Temp	8		s	86	000 : Cool	000 : Cool
					001 : Normal	001 : Normal
					002 : Warm	002 : Warm
Ambient Light Sensor	8		s	95	000: Off	000: Off
					001: On	001: On
RTC Year	8		s	98	000 ~ 099	000 ~ 099
RTC Month	8		s	99	001 ~ 012	001 ~ 012
RTC Day	8		s	9A	001 ~ 031	001 ~ 031
RTC Hour	8		s	9B	000 ~ 023	000 ~ 023
RTC Minute	8		s	9C	000 ~ 059	000 ~ 059
Touch Feature	8		s	9E	000: Off	000: Off
					001: On	001: On
Power Save	8		s	A9	000: Off	000: Off
					001: Low	001: Low
					002: High	002: High
Switch on Staus	8		s	AB	000 : Power Off	000 : Power Off
					001 : Force On	001 : Force On
					002 : Last Status	002 : Last Status

On/Off Timer	14	s	E0	<p>Byte1~Byte9</p> <p>(1) Byte1: Decide which Timer is selected, and its enable/disable setting.</p> <p>Byte1[3:0]=0x1~0x07. There are totally 7 Timers, this value is used to decide which Timer is selected.</p> <p>Byte1[7]: Reserved, should be 0.</p> <p>Byte1[6]: The Timer is enable or not. Byte1[6]=1 means enable.</p> <p>Byte1[5]: The On Timer is enable or not. Byte1[5]=1 means enable.</p> <p>Byte1[4]: The Off Timer is enable or not. Byte1[4]=1 means enable.</p> <p>(2) Byte2: The Day of the On/Off Timer. bit0 for Sunday, bit1 for Monday, bit2 for Tuesday, bit3 for Wednesday, bit4 for Thursday, bit5 for Friday, bit6 for Saturday, bit7 for Everday.</p> <p>(3) Byte3: The Hour of the On Timer. Byte3=0x00~0x17.</p> <p>(4) Byte4: The Minute of the On Timer. Byte4=0x00~0x3B.</p> <p>(5) Byte5: The Hour of the Off Timer. Byte5=0x00~0x17.</p> <p>(6) Byte6: The Minute of the Off Timer. Byte6=0x00~0x3B.</p> <p>(7) Byte7: Select the Video Source. 0x00=VGA, 0x01=HDMI1, 0x02=HDMI2, 0x03=AV, 0x04=YPbPr, 0x05=S-Video, 0x06=DVI, 0x07=DisplayPort, 0x08=SDI, 0x09=Multi-Media. 0x0A=Network, 0x0B=USB Display, 0x15=HDMI3, 0x16=HDMI4, 0x17=HDMI5, 0x1F=VGA2, 0x20=VGA3, 0x21=VGA4, 0x29=DP2, 0x2A=DP3, 0x2B=DP3, 0x33=Type C, 0x65=Android, 0x66=OPS, 0xC8=Android Home, 0xFF=Default (系統關機前的訊號)</p>	<p>Byte1~Byte9</p> <p>(1) Byte1: Decide which Timer is selected, and its enable/disable setting.</p> <p>Byte1[3:0]=0x1~0x07. There are totally 7 Timers, this value is used to decide which Timer is selected.</p> <p>Byte1[7]: Reserved, should be 0.</p> <p>Byte1[6]: The Timer is enable or not. Byte1[6]=1 means enable.</p> <p>Byte1[5]: The On Timer is enable or not. Byte1[5]=1 means enable.</p> <p>Byte1[4]: The Off Timer is enable or not. Byte1[4]=1 means enable.</p> <p>(2) Byte2: The Day of the On/Off Timer. bit0 for Sunday, bit1 for Monday, bit2 for Tuesday, bit3 for Wednesday, bit4 for Thursday, bit5 for Friday, bit6 for Saturday, bit7 for Everday.</p> <p>(3) Byte3: The Hour of the On Timer. Byte3=0x00~0x17.</p> <p>(4) Byte4: The Minute of the On Timer. Byte4=0x00~0x3B.</p> <p>(5) Byte5: The Hour of the Off Timer. Byte5=0x00~0x17.</p> <p>(6) Byte6: The Minute of the Off Timer. Byte6=0x00~0x3B.</p> <p>(7) Byte7: Select the Video Source. 0x00=VGA, 0x01=HDMI1, 0x02=HDMI2, 0x03=AV, 0x04=YPbPr, 0x05=S-Video, 0x06=DVI, 0x07=DisplayPort, 0x08=SDI, 0x09=Multi-Media. 0x0A=Network, 0x0B=USB Display, 0x15=HDMI3, 0x16=HDMI4, 0x17=HDMI5, 0x1F=VGA2, 0x20=VGA3, 0x21=VGA4, 0x29=DP2, 0x2A=DP3, 0x2B=DP3, 0x33=Type C, 0x65=Android, 0x66=OPS, 0xC8=Android Home, 0xFF=Default</p>
--------------	----	---	----	--	---

					源). Other values are reserved. (8) Byte8~9 are reserved, and should be 0x00.	(系統關機前的訊號源). Other values are reserved. (8) Byte8~9 are reserved, and should be 0x00.
WOL	8		s	F0	000: Off 001: On	000: Off 001: On
Image Noise Reduction	8		s	F1	000: Off 001: On	000: Off 001: On
Eyecare	8		s	F3	000: Off 001: On	000: Off 001: On
HDMI out	8		s	F4	000: Off 001: On	000: Off 001: On

Sleep Timer	8		s	F5	000 : Off	000 : Off
					001 : 1 min	001 : 1 min
					005 : 5 min	005 : 5 min
					010 : 10 min	010 : 10 min
					020 : 20 min	020 : 20 min
					030 : 30 min	030 : 30 min
					040 : 40 min	040 : 40 min
					050 : 50 min	050 : 50 min
					060 : 60 min (1 hrs)	060 : 60 min (1 hrs)
					120 : 2 hrs	120 : 2 hrs
					180 : 3 hrs	180 : 3 hrs
240 : 4 hrs	240 : 4 hrs					
Main Shortcut	8		s	F8	000: Off	000: Off
					001: On	001: On
Ethernet	8		s	FC	000: Off	000: Off
					001: On	001: On
Wifi	8		s	FD	000: Off	000: Off
					001: On	001: On

Get-function listing

The PC can interrogate the LCD Monitor for specific information. The Get-Function packet format consists of 5 bytes which are similar to the Set-Function packet structure. Note that the "Value" byte is always = 00.

Get-function description

Item	Description
Length	Total Bytes of messages excluding "CR"
TV ID	Identification for each of TV TV ID is "01" for LAN control & RS232 control
Command Type	Identify command type, "g" (0x67h): Get Command
Command	Function command code: One byte ASCII code
Value [1~3]	Three bytes ASCII that defines the value NOTE: To get backlight sensor, thermal sensor, and ambient sensor, you need four bytes ASCII that defines the value and the length is 9.
CR	0x0D

Get-function format

Send: (Command Type="g")

Name	Length	ID	Command type	Command	Value1	Value2	Value3	CR
Byte count	1 Byte	2 Byte	1 Byte	1 Byte	1 Byte	1 Byte	1 Byte	1 Byte
Bytes order	1	2~3	4	5	6	7	8	9

Reply: (Command Type="r" or "-")

If the Command is valid, Command Type ="r"

Name	Length	ID	Command type	Command	Value1	Value2	Value3	CR
Byte count	1 Byte	2 Byte	1 Byte	1 Byte	1 Byte	1 Byte	1 Byte	1 Byte
Bytes order	1	2~3	4	5	6	7	8	9

If the Command is Not valid, Command Type="-"

Name	Length	ID	Command type	CR
Byte count	1 Byte	2 Byte	1 Byte	1 Byte
Bytes order	1	2~3	4	5

Example 1: Get Brightness and this command is valid.

The Brightness value is 67.

Send (Hex Format)

Name	Length	ID	Command type	Command	Value1	Value2	Value3	CR
Hex	0x38	0x30 0x31	0x67	0x62	0x30	0x30	0x30	0x0D

Reply (Hex Format)

Name	Length	ID	Command type	Command	Value1	Value2	Value3	CR
Hex	0x38	0x30 0x31	0x72	0x62	0x30	0x36	0x37	0x0D

Example 3: Get Balance from and this command is valid.

The Balance value is 32.

Send (Hex Format)

Name	Length	ID	Command type	Command	Value1	Value2	Value3	CR
Hex	0x38	0x30 0x31	0x67	0x39	0x30	0x30	0x30	0x0D

Reply (Hex Format)

Name	Length	ID	Command type	Command	Value1	Value2	Value3	CR
Hex	0x38	0x30 0x31	0x72	0x39	0x30	0x33	0x32	0x0D

Example 4: Get Balance, but the Balance command ID is error and it is NOT in the command table.

Send (Hex Format)

Name	Length	ID	Command type	Command	Value1	Value2	Value3	CR
Hex	0x38	0x30 0x31	0x67	0xD7	0x30	0x30	0x30	0x0D

Reply (Hex Format)

Name	Length	ID	Command type	CR
Hex	0x34	0x30 0x31	0x2D	0x0D

Example 5: Get Operation time from system and this command is valid.

The System Operation time value is 1786 (ASCII code).

Send (Hex Format)

Name	Length	ID	Command type	Command	Value1	Value2	Value3	Value4	Value5	CR
Hex	0x38	0x30 0x31	0x67	0x76	0x30	0x30	0x30	0x30	0x30	0x0D

Reply (Hex Format)

Name	Length	ID	Command type	Command	Value1	Value2	Value3	Value4	Value5	CR
Hex	0x38	0x30 0x31	0x72	0x76	0x30	0x31	0x37	0x38	0x36	0x0D

Example 6: Get CO2 Value from System and this command is valid.

The lux value is 786 (ASCII code).

Send (Hex Format)

Name	Length	ID	Command type	Command	Value1	Value2	Value3	Value4	Value5	CR
Hex	0x38	0x30 0x31	0x67	0xAB	0x30	0x30	0x30	0x30	0x30	0x0D

Reply (Hex Format)

Name	Length	ID	Command type	Command	Value1	Value2	Value3	Value4	Value5	CR
Hex	0x38	0x30 0x31	0x72	0xAB	0x30	0x30	0x37	0x38	0x36	0x0D

PC Get-function command to IFP

Get Function	Len	ID	Cmd Type	Cmd Code (Hex)	RS232	LAN
Model Info	20		g	20	<p>(1) Input value: Byte1 - Byte2 - Byte3...Byte15 Byte2~Byte11=0x00 Byte1=0x01: Get Customer Name Byte1=0x02: Get Customer Model Name Byte1=0x04: Get Scaler Firmware Version Byte1=0x05: Get LAN Firmware Version Byte1=0x06: Get Serial Number</p> <p>(2) Return value: Byte1 - Byte2 - Byte3...Byte15 The Byte1 value at the return value should be the same as the value of Byte1 at input value. Byte2~Byte15 should be ASCII format. Ex: If Customer=Generic, Byte1=0x01, Byte2='G', Byte3='e',...Byte8='c', Byte9~Byte11=0x00. Ex: If the Scaler Firmware Version=1.02, Byte1=0x03, Byte2='1', Byte3='.', Byte4='0', Byte5='2', Byte6~Byte11=0x00.</p>	<p>(1) Input value: Byte1 - Byte2 - Byte3...Byte15 Byte2~Byte11=0x00 Byte1=0x01: Get Customer Name Byte1=0x02: Get Customer Model Name Byte1=0x04: Get Scaler Firmware Version Byte1=0x05: Get LAN Firmware Version Byte1=0x06: Get Serial Number</p> <p>(2) Return value: Byte1 - Byte2 - Byte3...Byte15 The Byte1 value at the return value should be the same as the value of Byte1 at input value. Byte2~Byte15 should be ASCII format. Ex: If Customer=Generic, Byte1=0x01, Byte2='G', Byte3='e',...Byte8='c', Byte9~Byte11=0x00. Ex: If the Scaler Firmware Version=1.02, Byte1=0x03, Byte2='1', Byte3='.', Byte4='0', Byte5='2', Byte6~Byte11=0x00.</p>
Signal Status	8		g	22	000: Signal unstable	000: Signal unstable
					001: Signal stable (Active Sync exists)	001: Signal stable (Active Sync exists)
Treble	8		g	37	000~100	000~100
Bass	8		g	38	000~100	000~100
Balance	8		g	39	000~100	000~100
Contrast	8		g	61	000 ~ 100	000 ~ 100
Brightness	8		g	62	000 ~ 100	000 ~ 100
Sound Mode	8		g	65	000 : Movie	000 : Movie
					001 : Standard	001 : Standard
					002: Custom (User)	002: Custom (User)

					003 : Class	003 : Class
					004 : Meeting	004 : Meeting
Volume	8		g	66	000 ~ 100	000 ~ 100
Mute	8		g	67	000: Off	000: Off
					001: On	001: On
IR Control	8		g	68	000: Disable	000: Disable
					001: Enable	001: Enable
Button&IR Control	8		g	69	000: Disable	000: Disable
					001: Enable	001: Enable
Video Source	8		g	6A	000 : VGA	000 : VGA
					001 : HDMI1	001 : HDMI1
					002: HDMI2	002: HDMI2
					021 : HDMI3	021 : HDMI3
					051 : Type-C (RE03)	051 : Type-C (RE03)
					101 : Android	101 : Android
					103 : OPS	103 : OPS
Power	8		g	6C	X	000 : Monitor Off
					001 : On	001 : Monitor On
					002 : Standby (or android off)	X
Button Control	8		g	73	000: Disable	000: Disable
					001: Enable	001: Enable
Operation Time	10		g	76	00000 ~ 99999	00000 ~ 99999
Aspect Ratio	8		g	77	000 : 16:9	000 : 16:9
					002 : PTP	002 : PTP
Language	8		g	78	000: English	000: English
					001: Français	001: Français
					002: Español	002: Español
					003: 繁中	003: 繁中
					004: 简中	004: 简中
					005: Português	005: Português
					006: German	006: German
					007: Dutch	007: Dutch
					008: Polish	008: Polish
					009: Russia	009: Russia
					010:Czech	010:Czech
					011:Danish	011:Danish
					012:Swedish	012:Swedish
					013:Italian	013:Italian
					014:Romanian	014:Romanian

					015:Norwegian	015:Norwegian
					016:Finnish	016:Finnish
					017:Greek	017:Greek
					018:Turkish	018:Turkish
					019:Arabic	019:Arabic
					020:Japanese	020:Japanese
					021: Thailand	021: Thailand
					022: Korean	022: Korean
					023 : Hungarian	023 : Hungarian
					024 : Persian	024 : Persian
					025 : Vietnamese	025 : Vietnamese
					026 : Indonesia	026 : Indonesia
					027 : Hebrew (希伯來語)	027 : Hebrew (希伯來語)
Touch Feature	8		g	9E	000: Off	000: Off
					001: On	001: On
Picture Mode	8		g	B1	000: Standard	000: Standard
					001: Bright	001: Bright
					002 : Soft	002 : Soft
					003 : ECO	003 : ECO
					005 : Custom 1	005 : Custom 1
					006 : Custom 2	006 : Custom 2
					007 : Custom 3	007 : Custom 3
Backlight	8		g	B4	000 ~ 100	000 ~ 100
DCR	8	1	g	B5	000: Off	000: Off
					001: On	001: On
Color Temp	8		g	B6	000 : Cool	000 : Cool
					001 : Normal	001 : Normal
					002 : Warm	002 : Warm
Ambient Light Sensor	8		g	C5	000: Off	000: Off
					001: On	001: On
RTC Year	8		g	C8	000 ~ 099	000 ~ 099
RTC Month	8		g	C9	001 ~ 012	001 ~ 012
RTC Day	8		g	CA	001 ~ 031	001 ~ 031
RTC Hour	8		g	CB	000 ~ 023	000 ~ 023
RTC Minute	8		g	CC	000 ~ 059	000 ~ 059
Power Save	8		g	D9	000: Off	000 : Off
					001: Low	001 : Low
					002: High	002 : High
	8	1	g	DA	000 : Power Off	000 : Power Off

Switch on				001 : Force On	001 : Force On
Staus				002 : Last Status	002 : Last Status
On/Off Timer	14	g	EO	<p>Input value: Byte1 - Byte2 - Byte3...Byte9</p> <p>(1) Byte1[3:0]: The Number of the On/Off Timer. There are totally 7 On/Off Timers, and this byte is used to selected which timer is going to be accessed.</p> <p>(2) Byte1[7:4] is reserved, should be 0.</p> <p>(3) Byte2~9 are reserverd, should be 0x00.</p> <p>Return value: Byte1 - Byte2 - Byte3...Byte9</p> <p>(1) Byte1[3:0]: Should retuen the same value as Byte1 at Input value.</p> <p>Byte1[7]: Reserved, should be 0.</p> <p>Byte1[6]: The Timer is enable or not.</p> <p>Byte1[6]=1 means enable.</p> <p>Byte1[5]: The On Timer is enable or not.</p> <p>Byte1[5]=1 means enable.</p> <p>Byte1[4]: The Off Timer is enable or not.</p> <p>Byte1[4]=1 means enable.</p> <p>(2) Byte2: The Day of the On/Off Timer. bit0 for Sunday, bit1 for Monday, bit2 for Tuesday, bit3 for Wednesday, bit4 for Thursday, bit5 for Friday, bit6 for Saturday, bit7 for Everday.</p> <p>(3) Byte3: The Hour of the On Timer. Byte3=0x00~0x17.</p> <p>(4) Byte4: The Minute of the On Timer. Byte4=0x00~0x3B.</p> <p>(5) Byte5: The Hour of the Off Timer. Byte5=0x00~0x17.</p> <p>(6) Byte6: The Minute of the Off Timer. Byte6=0x00~0x3B.</p> <p>(7) Byte7: Select the Video Source. 0x00=VGA, 0x01=HDMI1, 0x02=HDMI2, 0x03=AV, 0x04=YPbPr, 0x05=S-Video, 0x06=DVI, 0x07=DisplayPort, 0x08=SDI, 0x09=Multi-Media. 0x0A=Network,</p>	<p>Input value: Byte1 - Byte2 - Byte3...Byte9</p> <p>(1) Byte1[3:0]: The Number of the On/Off Timer. There are totally 7 On/Off Timers, and this byte is used to selected which timer is going to be accessed.</p> <p>(2) Byte1[7:4] is reserved, should be 0.</p> <p>(3) Byte2~9 are reserverd, should be 0x00.</p> <p>Return value: Byte1 - Byte2 - Byte3...Byte9</p> <p>(1) Byte1[3:0]: Should retuen the same value as Byte1 at Input value.</p> <p>Byte1[7]: Reserved, should be 0.</p> <p>Byte1[6]: The Timer is enable or not.</p> <p>Byte1[6]=1 means enable.</p> <p>Byte1[5]: The On Timer is enable or not.</p> <p>Byte1[5]=1 means enable.</p> <p>Byte1[4]: The Off Timer is enable or not.</p> <p>Byte1[4]=1 means enable.</p> <p>(2) Byte2: The Day of the On/Off Timer. bit0 for Sunday, bit1 for Monday, bit2 for Tuesday, bit3 for Wednesday, bit4 for Thursday, bit5 for Friday, bit6 for Saturday, bit7 for Everday.</p> <p>(3) Byte3: The Hour of the On Timer. Byte3=0x00~0x17.</p> <p>(4) Byte4: The Minute of the On Timer. Byte4=0x00~0x3B.</p> <p>(5) Byte5: The Hour of the Off Timer. Byte5=0x00~0x17.</p> <p>(6) Byte6: The Minute of the Off Timer. Byte6=0x00~0x3B.</p> <p>(7) Byte7: Select the Video Source. 0x00=VGA, 0x01=HDMI1, 0x02=HDMI2, 0x03=AV, 0x04=YPbPr, 0x05=S-Video, 0x06=DVI, 0x07=DisplayPort, 0x08=SDI, 0x09=Multi-Media. 0x0A=Network,</p>

				<p>0x0B=USB Display, 0x15=HDMI3, 0x16=HDMI4, 0x17=HDMI5, 0x1F=VGA2, 0x20=VGA3, 0x21=VGA4, 0x29=DP2, 0x2A=DP3, 0x2B=DP3, 0x33=Type C, 0x65=Android, 0x66=OPS, 0xC8=Android Home, 0xFF=Default (系統關機前的訊號源). Other values are reserved. (8) Byte8~9 are reserved, and should be 0x00.</p>	<p>0x0B=USB Display, 0x15=HDMI3, 0x16=HDMI4, 0x17=HDMI5, 0x1F=VGA2, 0x20=VGA3, 0x21=VGA4, 0x29=DP2, 0x2A=DP3, 0x2B=DP3, 0x33=Type C, 0x65=Android, 0x66=OPS, 0xC8=Android Home, 0xFF=Default (系統關機前的訊號源). Other values are reserved. (8) Byte8~9 are reserved, and should be 0x00.</p>
Network Setting	14	g	E1	<p>Input Value: Byte1 - Byte2 - Byte3...Byte9 (1) Byte1=0x00: IP Setup Mode Byte1=0x01: IP Address Byte1=0x02: Get Subnet Mask Byte1=0x03: Default Gateway Byte1=0x04: Primary DNS Byte1=0x05: Secondary DNS Byte1=0x06: MAC Address (2) Byte2~9 are reserved, should be 0x00. Return value: Byte1 - Byte2 - Byte3...Byte9 The Byte1 at the return value should be the same as the value of Byte1 at Input</p>	<p>Input Value: Byte1 - Byte2 - Byte3...Byte9 (1) Byte1=0x00: IP Setup Mode Byte1=0x01: IP Address Byte1=0x02: Get Subnet Mask Byte1=0x03: Default Gateway Byte1=0x04: Primary DNS Byte1=0x05: Secondary DNS Byte1=0x06: 當下連線網路 MAC Address Byte1=0x07: Ethernet (RJ45) MAC Address (2) Byte2~9 are reserved, should be 0x00. Return value: Byte1 - Byte2 -</p>

					<p>value. Byte2~Byte15 should be hex value format</p> <p>(1) If Byte1=0x00(IP Setup Mode) at Input value, the return value should be</p> <p style="padding-left: 40px;">Byte1=0x00</p> <p style="padding-left: 40px;">Byte2=0x00: Manual</p> <p style="padding-left: 80px;">0x01: DHCP</p> <p style="padding-left: 40px;">Byte3~9 are reserved, should be 0x00.</p> <p>(2) If Byte1=0x01(IP Address) at Input value, the return value should be</p> <p style="padding-left: 40px;">Ex: IP address=169.254.81.38</p> <p style="padding-left: 40px;">Byte1=0x01 (same as Byte1 at Input value)</p> <p style="padding-left: 40px;">Byte2=0xA9 (=169), Byte3=0xFE (=254), Byte4=0x51(=81), Byte5=0x26 (=38)</p> <p style="padding-left: 40px;">Byte6~9 are reserved, should be 0x00.</p> <p>(3) If Byte1=0x02~0x05 at Input value, refer to (2)</p> <p>(4) If Byte1=0x06(MAC Address) at Input value, the return value should be</p> <p style="padding-left: 40px;">Ex: MAC address=00:22:64:7E:2C:82</p> <p style="padding-left: 40px;">Byte1=0x06 (same as Byte1 at Input value)</p> <p style="padding-left: 40px;">Byte2=0x00, Byte3=0x22, Byte4=0x64, Byte5=0x7E, Byte6=0x2C, Byte7=0x82</p> <p style="padding-left: 40px;">Byte8~9 are reserved, should be 0x00.</p>	<p>Byte3...Byte9</p> <p>The Byte1 at the return value should be the same as the value of Byte1 at Input value. Byte2~Byte15 should be hex value format</p> <p>(1) If Byte1=0x00(IP Setup Mode) at Input value, the return value should be</p> <p style="padding-left: 40px;">Byte1=0x00</p> <p style="padding-left: 40px;">Byte2=0x00: Manual</p> <p style="padding-left: 80px;">0x01: DHCP</p> <p style="padding-left: 40px;">Byte3~9 are reserved, should be 0x00.</p> <p>(2) If Byte1=0x01(IP Address) at Input value, the return value should be</p> <p style="padding-left: 40px;">Ex: IP address=169.254.81.38</p> <p style="padding-left: 40px;">Byte1=0x01 (same as Byte1 at Input value)</p> <p style="padding-left: 40px;">Byte2=0xA9 (=169), Byte3=0xFE (=254), Byte4=0x51(=81), Byte5=0x26 (=38)</p> <p style="padding-left: 40px;">Byte6~9 are reserved, should be 0x00.</p> <p>(3) If Byte1=0x02~0x05 at Input value, refer to (2)</p> <p>(4) If Byte1=0x06(MAC Address) at Input value, the return value should be</p> <p style="padding-left: 40px;">Ex: MAC address=00:22:64:7E:2C:82</p> <p style="padding-left: 40px;">Byte1=0x06 (same as Byte1 at Input value)</p> <p style="padding-left: 40px;">Byte2=0x00, Byte3=0x22, Byte4=0x64, Byte5=0x7E, Byte6=0x2C, Byte7=0x82</p> <p style="padding-left: 40px;">Byte8~9 are reserved, should be 0x00.</p>
WOL	8		g	F0	000: Off	000: Off
					001: On	001: On
Image Noise Reduction	8		g	F1	000: Off	000: Off
					001: On	001: On
Eyecare	8		g	F3	000: Off	000: Off

					001: On	001: On
HDMIOut	8		g	F4	000: Off	000: Off
					001: On	001: On
Sleep Timer	8		g	F5	000 : Off	000 : Off
					001 : 1 min	001 : 1 min
					005 : 5 min	005 : 5 min
					010 : 10 min	010 : 10 min
					020 : 20 min	020 : 20 min
					030 : 30 min	030 : 30 min
					040 : 40 min	040 : 40 min
					050 : 50 min	050 : 50 min
					060 : 60 min (1 hrs)	060 : 60 min (1 hrs)
					120 : 2 hrs	120 : 2 hrs
					180 : 3 hrs	180 : 3 hrs
240 : 4 hrs	240 : 4 hrs					
Main Shortcut	8		g	F8	000: Off	000: Off
					001: On	001: On
Ethernet	8		g	FC	000: Off	000: Off
					001: On	001: On
Wifi	8		g	FD	000: Off	000: Off
					001: On	001: On